

## DC MOTOR

### 15W

### □70mm

### DIMENSIONS

K7DS□N□

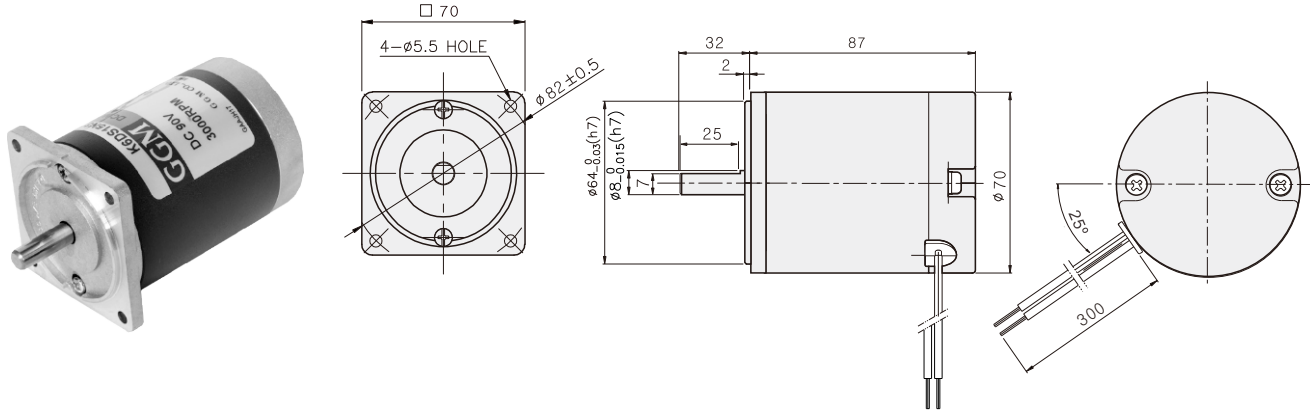

### CONNECTION DIAGRAMS

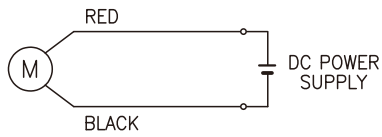

CW When '+' power is applied to the red line.  
 CCW When '+' power is applied to the black line.  
 ※ Direction of rotation when viewed from the front side of the output shaft

### SPECIFICATIONS

Model	Output (W)	Voltage (V)	RATED			Start T. (N·m/kgf·cm)	Starting Current (A)
			Speed (rpm)	Torque (N·m/kgf·cm)	Current (A)		
K7D□15N1	15	12	3000	0.05/0.5	3.1	0.29/2.9	16
K7D□15N2		24			1.4	0.35/3.5	9
K7D□15N3		90			0.3	0.39/3.9	3

\* □ : SHAFT SHAPE (S : STRAIGHT, G : PINION)

## GEARHEAD DIMENSIONS

DECIMAL GEARHEAD  
K7G10BX

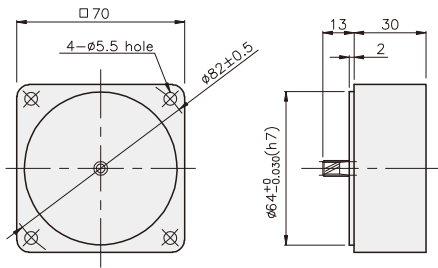

GEARHEAD  
K7G□B(C)

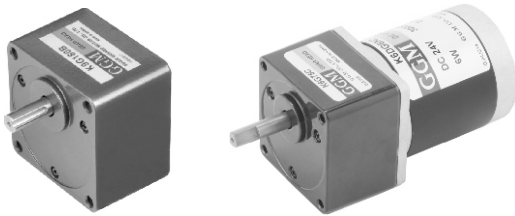
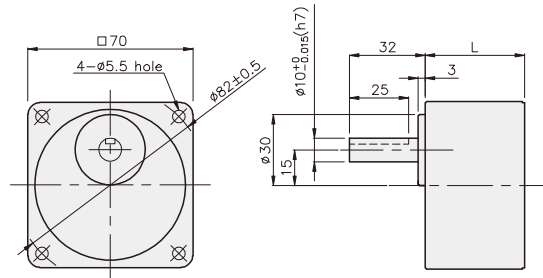

### KEY SPEC

● KEY

● KEY GROOVE

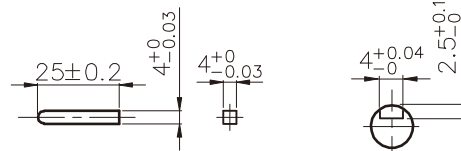

### DIMENSION TABLE

PART No	L	Application Model	Mounting BOLT
01	32	K7G3~18B(C)	M5 P0.8 X 50
02	42	K7G20~200B(C)	M5 P0.8 X 65
03	30	K7G10BX	M5 P0.8 X 90

### WEIGHT

PART	WEIGHT(kg)	
MOTOR	0.95	
K7G10BX	0.32	
GEAR HEAD	K7G3~18B(C)	0.38
	K7G20~40B(C)	0.46
	K7G50~200B(C)	0.51

K7DG15N□ + K7G□B(C)

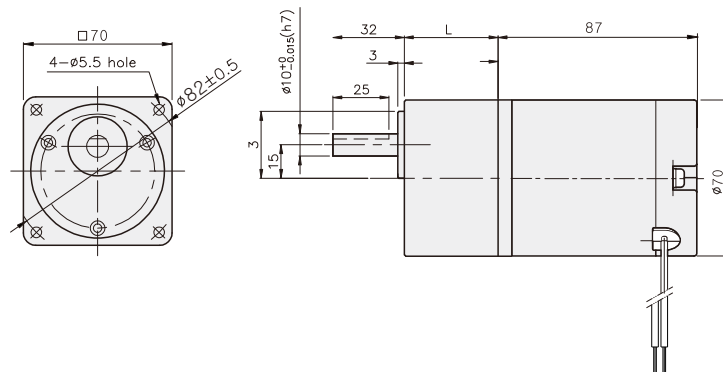

## RATED TORQUE OF GEARHEAD

### ● K7G□B(C)

unit = above : N·m / below : Kgf·cm

Model	Speed (rpm)	1000	833	600	500	400	333	300	240	200	167	150	120	100	83	75	60	50	40	33	30	25	20	17	15
		Ratio	3	3.6	5	6	7.5	9	10	12.5	15	18	20	25	30	36	40	50	60	75	90	100	120	150	180
K7DG15N□	0.12	0.14	0.20	0.24	0.30	0.36	0.39	0.49	0.59	0.71	0.71	0.89	1.07	1.28	1.42	1.60	1.92	2.40	2.88	3.20	3.83	4.79	5	5	
	1.2	1.4	2.0	2.4	3.0	3.6	3.9	4.9	5.9	7.1	7.1	8.9	10.7	12.8	14.2	16.0	19.2	24.0	28.8	32.0	38.3	47.9	50	50	

\* Gearhead and decimal gearhead are sold separately.

\* The code in □ of gearhead model is for gear ratio.

\*   color indicates that the output shaft of the geared motor rotates in the same direction as the output shaft of the motor. Others indicate rotation in the opposite direction.

\* If you are to have less ratio than the ratio in the table, you can install the decimal gearhead, which has one tenth of the ratio, between the gearhead and the motor. In this case, the permissible torque is 5N·m/50kgfcm.