

SPEED CONTROL & BRAKE MOTOR

180W

□90mm

K9RS180F□-D

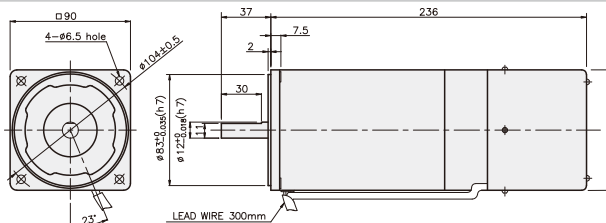

SPEED CONTROL & BRAKE MOTOR

SPECIFICATIONS

180W 30分 定格, 4極

Model	Voltage (V)	Frequency (Hz)	Speed Range (rpm)	Permissible Torque		Start T. (N*m/Kgf*cm)	Current (A)	Condenser (μF)	Friction T. (N*m/Kgf*cm)
				1200rpm (N*m/Kgf*cm)	90rpm (N*m/Kgf*cm)				
K9R□180FJ-D	100	50	90 ~ 1400	0.88/8.8	0.33/3.3	0.5/5	5	40	1/10
			90 ~ 1700						
K9R□180FU-D	110	60	90 ~ 1700	1.1/11	0.38/3.8	0.58/5.8	5	30	1/10
	115						5.2		
K9R□180FL-D	200	50	90 ~ 1400	0.88/8.8	0.3/3	0.45/4.5	2.2	12	1/10
			90 ~ 1700			0.38/3.8			
K9R□180FC-D	220	50	90 ~ 1400	0.88/8.8	0.3/3	0.42/4.2	2.2	8	1/10
			90 ~ 1700			0.38/3.8			
		60	90 ~ 1400	0.95/9.5	0.32/3.2	0.48/4.8	2.4		
			90 ~ 1700			0.45/4.5	2.2		
K9R□180FD-D	240	50	90 ~ 1400	0.95/9.5	0.32/3.2	0.55/5.5	2	8	1/10

* □ : SHAFT 形状 (S : STRAIGHT, P : PINION)

RATED TORQUE OF GEARHEAD

● 単相 100V/115V

単位 = 上段 : N・m / 下段 : kgf・cm

Model	Ratio	Speed (rpm)																									
		3	3.6	5	6	7.5	9	10	12.5	15	18	20	25	30	36	40	50	60	75	90	100	120	150	180	200		
K9R□180F□-D K9P□BU, BUF	1200	100V/50Hz	2.14	2.57	3.56	4.28	5.35	6.42	7.13	8.02	9.62	11.55	12.83	14.43	17.32	20.79	23.09	28.87	30	30	30	30	30	30	30	30	30
		110V/60Hz	2.67	3.21	4.46	5.35	6.68	8.02	8.91	10.02	12.03	14.43	16.04	18.04	21.65	25.98	28.87	30	30	30	30	30	30	30	30	30	30
	90	100V/50Hz	0.80	0.96	1.34	1.60	2.00	2.41	2.67	3.01	3.61	4.33	4.81	5.41	6.50	7.79	8.66	10.83	12.99	14.61	17.54	19.49	23.38	29.23	30	30	30
		110V/60Hz	0.92	1.11	1.54	1.85	2.31	2.77	3.08	3.46	4.16	4.99	5.54	6.23	7.48	8.98	9.97	12.47	14.96	16.83	20.19	22.44	26.93	30	30	30	30

● 単相 200V/240V

単位 = 上段 : N・m / 下段 : kgf・cm

Model	Ratio	Speed (rpm)																									
		3	3.6	5	6	7.5	9	10	12.5	15	18	20	25	30	36	40	50	60	75	90	100	120	150	180	200		
K9R□180F□-D K9P□BU, BUF	1200	200V/220V/50Hz/60Hz	2.14	2.57	3.56	4.28	5.35	6.42	7.13	8.02	9.62	11.55	12.83	14.43	17.32	20.79	23.09	28.87	30	30	30	30	30	30	30	30	30
		230V/50Hz/60Hz/240V/50Hz	2.31	2.77	3.85	4.62	5.77	6.93	7.70	8.66	10.39	12.47	13.85	15.58	18.70	22.44	24.93	30	30	30	30	30	30	30	30	30	30
	90	200V/220V/50Hz/60Hz	0.73	0.87	1.22	1.46	1.82	2.19	2.43	2.73	3.28	3.94	4.37	4.92	5.90	7.09	7.87	9.84	11.81	13.29	15.94	17.71	21.26	26.57	30	30	30
		230V/50Hz/60Hz/240V/50Hz	0.78	0.93	1.30	1.56	1.94	2.33	2.59	2.92	3.50	4.20	4.67	5.25	6.30	7.56	8.40	10.50	12.60	14.17	17.01	18.90	22.67	28.34	30	30	30

* GEARHEAD・DECIMAL GEARHEADは別売です。

* GEARHEADの品名の中 □ には 減速比が入ります。

* 色がMOTORと同じ方向、その以外は反対方向です。

* 表の減速比よりもっと減速しようとする場合には、ギアヘッドとモーターの間に減速比10のDECIMAL GEARHEADを設置することが可能です。この場合許容トルクは 30N・m/300kgfcm です。

* 回転数はMOTORの動機回転数(50Hz:1500rpm, 60Hz:1800rpm)を基準にして減速比に割って計算しました。実際を回転数は負荷の大きさによって表示される数値より2~20% 小さいです。

GEARHEADS

CONNECTION DIAGRAMS

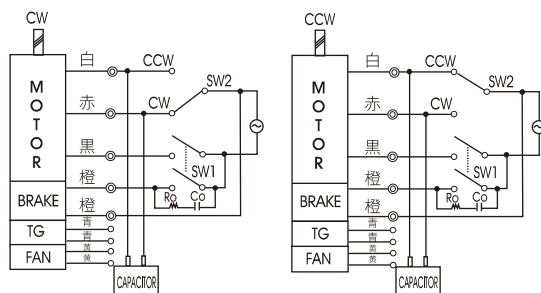

※回転方向は出力軸から見た場合

DIMENSIONS

K9P□BU



K9P□BUF



DECIMAL GEARHEAD

K9P10BX

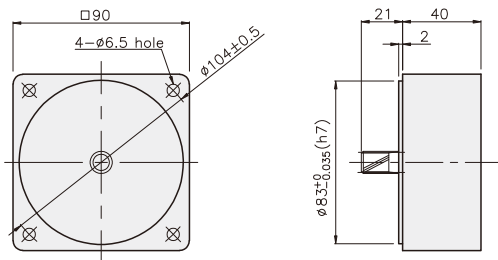

KEY SPEC

● KEY

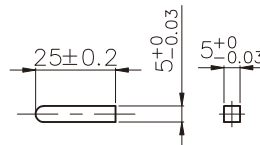

● KEY GROOVE

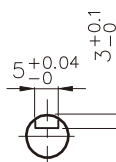

GEARHEAD

K9P□BU

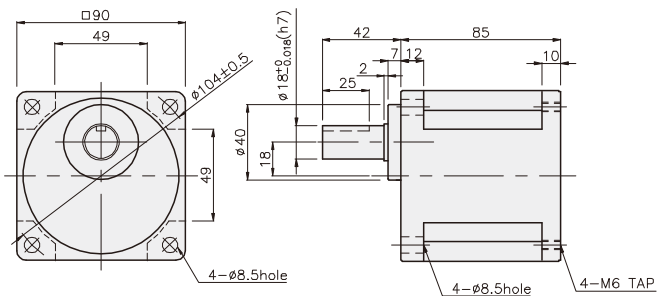

K9P□BUF

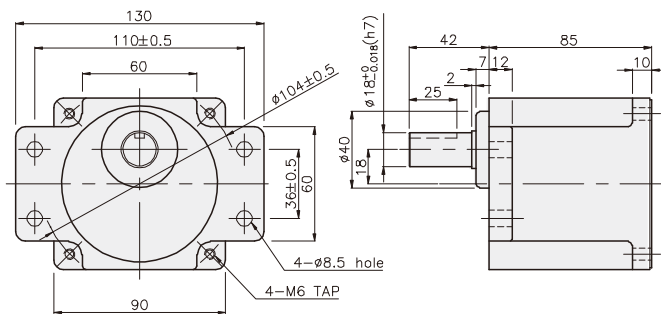

GEARHEADS

DIMENSIONS

K9RP180F□-D + K9P□BU



K9RP180F□-D + K9P□BUF



重さ

PART	WEIGHT(kg)
MOTOR	4,70
DECIMAL GEAR HEAD	0,62

寸法図表

品番	適用機種	取付BOLT
01	K9P3~200BU	M6 P1,0 X 20
02	K9P10BX	M6 P1,0 X 65

重さ

PART	WEIGHT(kg)
K9P3~10BU	1,44
K9P12,5~20BU	1,55
K9P25~60BU	1,69
K9P75~200BU	1,74

寸法図表

品番	適用機種	取付BOLT
01	K9P3~200BUF	M6 P1,0 X 20
02	K9P10BX	M6 P1,0 X 65

重さ

PART	WEIGHT(kg)
K9P3~10BUF	1,50
K9P12,5~20BUF	1,62
K9P25~60BUF	1,76
K9P75~200BUF	1,82

K9RP180F□-D + K9P□BU

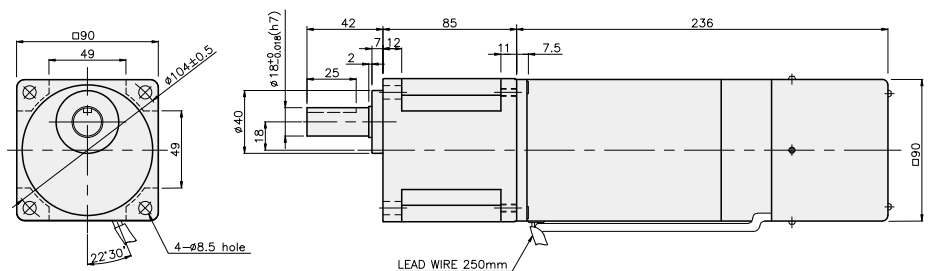

K9RP180F□-D + K9P□BUF

