

## REVERSIBLE MOTOR

### 6W

### □ 60mm

### LEAD WIRE TYPE TERMINAL BOX TYPE

K6RS6N□



K6RS6N□-T



### SPECIFICATIONS

6W continuous rating, four poles

Model		Voltage (V)	Frequency (Hz)	Current (A)	Start T. (N*m/Kgf*cm)	Rated T. (N*m/Kgf*cm)	Speed (rpm)	Condenser (μF)
K6R□6NJ(-T)		single-phase	100	50	0,25	0,035/0,35	0,049/0,49	1200
	60			0,23	0,04/0,4		1500	
K6R□6NU(-T)	110		60	0,2	0,045/0,45	0,04/0,4	1500	2,5
	115			0,2	0,05/0,5			
K6R□6NL(-T)	200		50	0,12	0,055/0,55	0,049/0,49	1200	1
			60	0,13		0,04/0,4	1500	
K6R□6NC(-T)	220		50	0,12	0,045/0,45	0,047/0,47	1250	0,8
			60	0,12		0,04/0,4	1500	
	230		50	0,15	0,055/0,55	0,047/0,47	1250	
			60	0,13	0,06/0,6	0,04/0,4	1500	
K6R□6ND(-T)	240		50	0,12	0,048/0,48	0,047/0,47	1250	0,6

### RATED TORQUE OF GEARHEAD

#### ● 50Hz

unit = above : N · m / below : kgfcm

Model	Speed(rpm)	500	416	300	250	200	166	150	120	100	83	75	60	50	41	37	30	25	20	16	15	12,5	10	8,3	7,5	6
Motor/ Gearhead	Ratio	3	3,6	5	6	7,5	9	10	12,5	15	18	20	25	30	36	40	50	60	75	90	100	120	150	180	200	250
K6R□6N□(-T)		0,11	0,14	0,19	0,23	0,29	0,34	0,38	0,48	0,57	0,69	0,69	0,86	1,03	1,23	1,37	1,54	1,85	2,31	2,78	3	3	3	3	3	3
K6G□B(C)		1,1	1,4	1,9	2,3	2,9	3,4	3,8	4,8	5,7	6,9	6,9	8,6	10,3	12,3	13,7	15,4	18,5	21,3	27,8	30	30	30	30	30	30

#### ● 60Hz

unit = above : N · m / below : kgfcm

Model	Speed(rpm)	600	500	360	300	240	200	180	144	120	100	90	72	60	50	45	36	30	24	20	18	15	12	10	9	7,2
Motor/ Gearhead	Ratio	3	3,6	5	6	7,5	9	10	12,5	15	18	20	25	30	36	40	50	60	75	90	100	120	150	180	200	250
K6R□6N□(-T)		0,10	0,12	0,16	0,19	0,24	0,29	0,32	0,41	0,49	0,58	0,58	0,73	0,87	1,05	1,17	1,31	1,57	1,97	2,36	2,62	3	3	3	3	3
K6G□B(C)		1,0	1,2	1,6	1,9	2,4	2,9	3,2	4,1	4,9	5,8	5,8	7,3	8,7	10,5	11,7	13,1	15,7	19,7	23,6	26,2	30	30	30	30	30

\* Gearhead and decimal gearhead are sold separately.

\* The code in □ of gearhead model is for gear ratio.

\*   color indicates that the output shaft of the geared motor rotates in the same direction as the output shaft of the motor. Others indicate rotation in the opposite direction.

\* If you are to have less ratio than the ratio in the table, you can install the decimal gearhead, which has one tenth of the ratio, between the gearhead and the motor. In this case, the permissible torque is 3N · m/30kgfcm.

\* RPM is based on motor's synchronous rpm (50HZ:1500rpm, 60HZ:1800rpm) and calculated by dividing gear ratio. Actual rpm is 2~20% less than indicating rpm according to load size.

## GEARHEADS

### DIMENSIONS

K6RS6N □

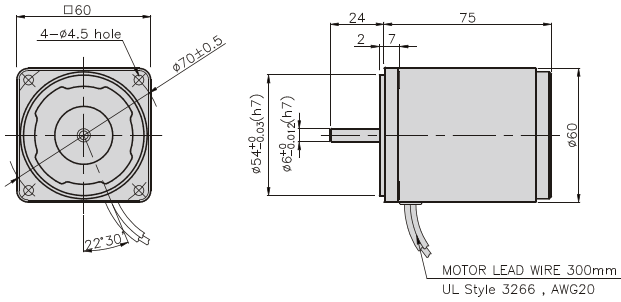

K6RS6N □-T

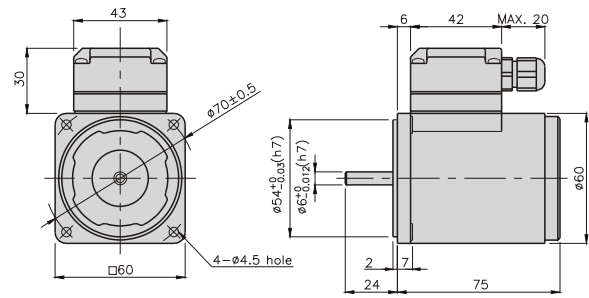

### CONNECTION DIAGRAMS

K6RS6N □

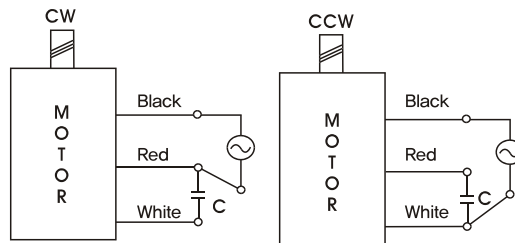

The direction of motor rotation is as viewed from the front shaft end of the motor

K6RS6N □-T

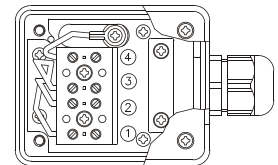
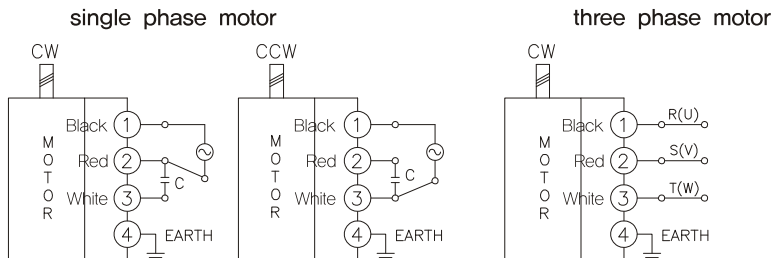

The direction of motor rotation is as viewed from the front shaft end of the motor

### DIMENSIONS

K6G □(C)



DECIMAL GEARHEAD

K6G10BX □

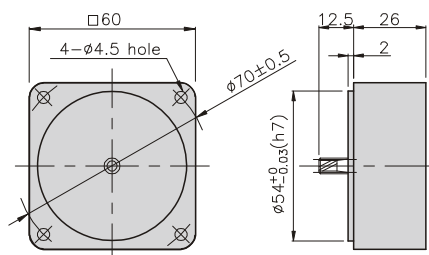

GEARHEAD

K6G □(C)

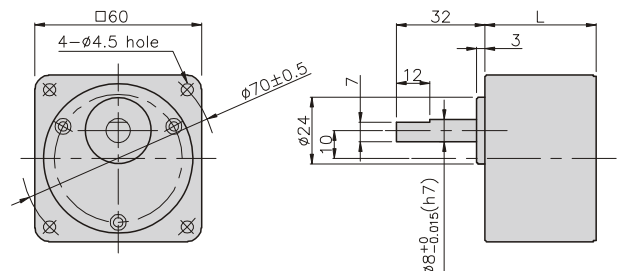

## GEARHEADS

### DIMENSIONS

K6RG6N□ + K6G□B(C)



K6RG6N□-T + K6G□B(C)



K6RG6N□ + K6G□B(C)

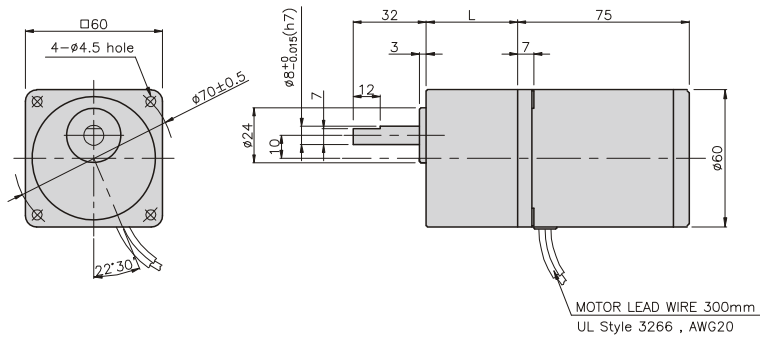

DIMENSION TABLE

PART No	L	Application Model	Mounting BOLT
01	30	K6G3~18B(C)	M4 P0,7 X 50
02	40	K6G20~250B(C)	M4 P0,7 X 60
03	26	K6G10BX	M4 P0,7 X 85

WEIGHT

PART	WEIGHT(kg)	
MOTOR	0,72	
DECIMAL GEAR HEAD	0,22	
GEAR HEAD	K6G3~18B(C)	0,26
	K6G20~40B(C)	0,33
	K6G50~250B(C)	0,36

K6RG6N□-T + K6G□B(C)

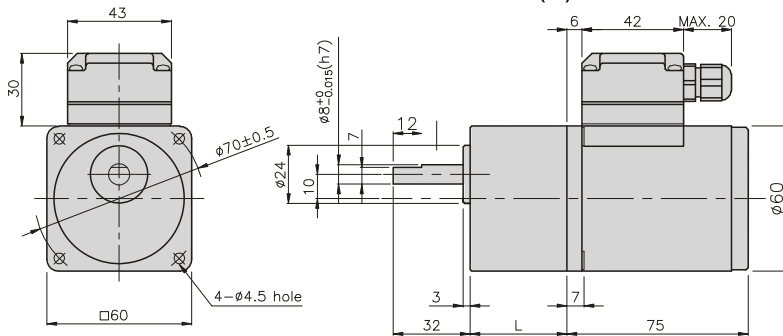

DIMENSION TABLE

PART No	L	Application Model	Mounting BOLT
01	30	K6G3~18B(C)	M4 P0,7 X 50
02	40	K6G20~250B(C)	M4 P0,7 X 60
03	26	K6G10BX	M4 P0,7 X 85

WEIGHT

PART	WEIGHT(kg)	
MOTOR	0,76	
DECIMAL GEAR HEAD	0,22	
GEAR HEAD	K6G3~18B(C)	0,26
	K6G20~40B(C)	0,33
	K6G50~250B(C)	0,36