

KGH-TYPE

DIMENSIONS

KGH SERIES

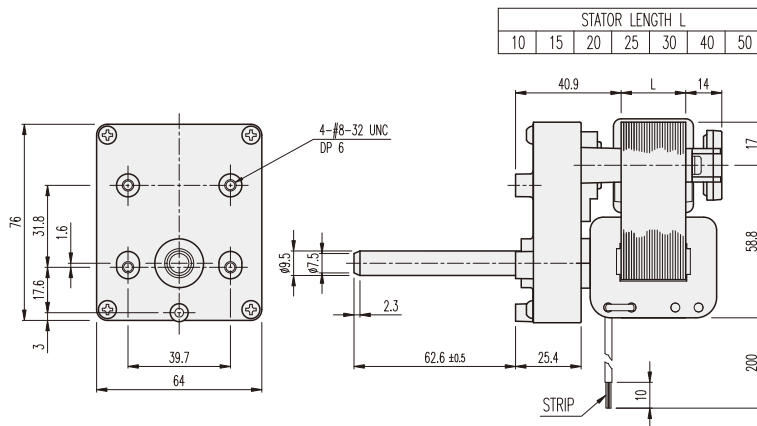
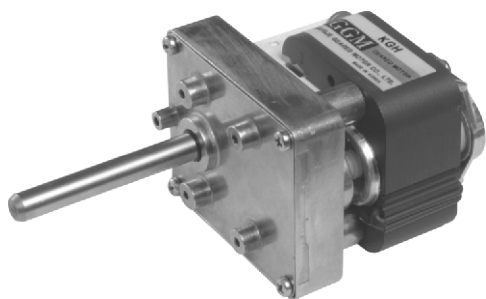

AT MAXIMUM EFFICIENCY (KGH-□□□□-KA61□□AE)

GEAR RATIO	MOTOR		KA6120AE				KA6130AE				KA6140AE				KA6150AE			
			50		60		50		60		50		60		50		60	
	rpm	kgf-cm	rpm	kgf-cm	rpm	kgf-cm	rpm	kgf-cm	rpm	kgf-cm	rpm	kgf-cm	rpm	kgf-cm	rpm	kgf-cm	rpm	kgf-cm
1/0015	160	1.0	193	0.8	160	1.8	193	1.3	160	2.4	193	1.8	160	3.0	193	2.4		
1/0023	104	1.5	126	1.2	104	2.8	126	2.0	104	3.7	126	2.8	104	4.6	126	3.7		
1/0036	67	2.1	81	1.7	67	3.9	81	2.8	67	5.2	81	3.9	67	6.5	81	5.2		
1/0058	41	3.4	50	2.7	41	6.3	50	4.6	41	8.3	50	6.3	41	10.5	50	8.5		
1/0075	32	4.4	39	3.5	32	8.2	39	5.9	32	10.8	39	8.1	32	13.6	39	10.9		
1/0133	18	7.8	22	6.2	18	14.5	22	10.5	18	19.1	22	14.4	18	24.0	22	19.4		
1/0220	11	11.5	13	9.2	11	21.7	13	15.6	11	28.4	13	21.5	11	35.8	13	28.9		

※ 上記のDATAはGENERAL TYPE SHADED POLE MOTORを適用した場合です。

※ 色の減速比は、モーターと出力軸の回転方向は同じです。

※ 標準では、F-TYPEです。