

## KGR5-TYPE

### DIMENSIONS

#### KGR5 SERIES

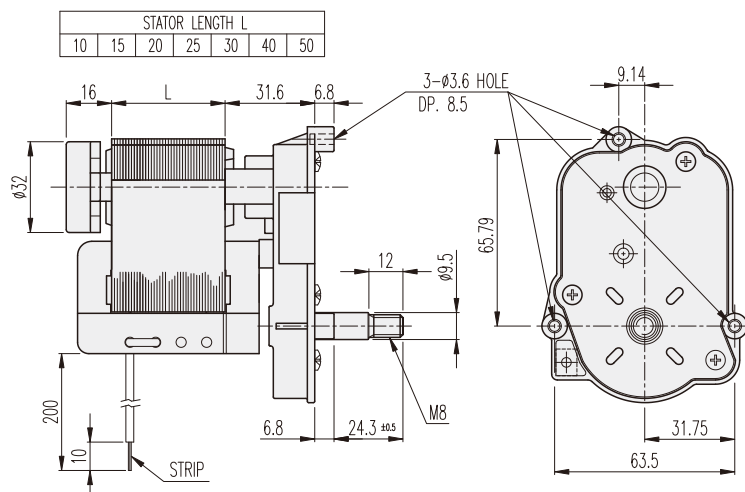

#### AT MAXIMUM EFFICIENCY (KGR5-□□□□-KA61□□AE)

MOTOR	KA6120AE				KA6130AE				KA6140AE				KA6150AE			
	50		60		50		60		50		60		50		60	
GEAR RATIO	rpm	kgf-cm	rpm	kgf-cm	rpm	kgf-cm	rpm	kgf-cm	rpm	kgf-cm	rpm	kgf-cm	rpm	kgf-cm	rpm	kgf-cm
1/0124	19.3	7.2	23.3	5.8	19.3	13.6	23.3	9.8	19.3	17.8	23.3	13.5	19.3	20	23.3	18.1
1/0192	12.5	11.2	15.1	9.0	12.5	21.0	15.1	15.1	12.5	20	15.1	20	12.5	20	15.1	20

\* 以上數據基於所應用的陰影極電動機的一般類型。  
 \* 減速比整個電動機和輸出軸的旋轉方向相同。